

CMSD2412 CMSD2412B

HD-SDI IR Camera



Key features

- 1.3 Mega Pixels
- 1/3" Sensor
- 3.6mm Lens
- 24pcs IR LEDs, 65ft(20m)
- Mechanical IR Cut Filter
- Aluminum housing
- DC 12V input

Dimensions

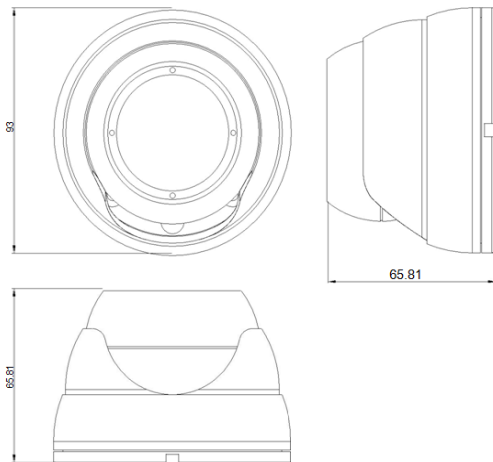

CMSD2412 CMSD2412B	
Camera	
Image Sensor	1/3" Sensor
Signal System	NTSC/PAL
Effective Pixels	1.3 Mega Pixels
Min. Illumination	0 Lux(Infrared Lamps Turn on)
Shutter Speed	NTSC: 1/60-1/50,000
	PAL: 1/50-1/50,000
Lens	3.6mm
Day & Night	ICR
Horizontal Resolution	NTSC/PAL:1280X720P
Synchronization	Internal
S/N Ratio	> 39dB (AGC off)
Digital Noise Reduction	2D DNR
White Balance	Auto Tracking White Balance
BLC	Auto
Auto Gain Control	Auto
Smart IR	Yes
General	
Working Temperature	-10℃ ~ 50℃
/Humidity	RH85% Max. (Non-condensing)
Power Supply	DC 12V
Power Consumption	< 4W(when the infrared lamps turn on)
Weather-proof rating	IP66
Infrared Red Lamps	24pcs
IR Range	65ft(20m)
Dimension	93mm x 93mm x 65.8mm
Weight	330g